



Application and Design Guide to EMI Shielding Honeycomb Vents





WARNING – USER RESPONSIBILITY

FAILURE OR IMPROPER SELECTION OR IMPROPER USE OF THE PRODUCTS DESCRIBED HEREIN OR RELATED ITEMS CAN CAUSE DEATH, PERSONAL INJURY AND PROPERTY DAMAGE.

- This document and other information from Parker-Hannifin Corporation, its subsidiaries and authorized distributors provide product or system options for further investigation by users having technical expertise.
- The user, through its own analysis and testing, is solely responsible for making the final selection of the system and components and assuring that all performance, endurance, maintenance, safety and warning requirements of the application are met. The user must analyze all aspects of the application, follow applicable industry standards, and follow the information concerning the product in the current product catalog and in any other materials provided from Parker or its subsidiaries or authorized distributors.
- To the extent that Parker or its subsidiaries or authorized distributors provide component or system options based upon data or specifications provided by the user, the user is responsible for determining that such data and specifications are suitable and sufficient for all applications and reasonably foreseeable uses of the components or systems.

Offer of Sale

The items described in this document are hereby offered for sale by Parker Hannifin Corporation its subsidiaries or its authorized

distributors. This offer and its acceptance are governed by the provisions stated in the detailed "Offer of Sale" elsewhere in this

document or available at www.chomerics.com or www.parker.com.

Contents

How to Use This Guide	1
What is an EMI Shielding Honeycomb Vent?	2
Application Design Assistance	2
Honeycomb Technical Specifications	5
Frames	7
Plating	10
Common Gasket Options	12
Honeycomb Performance Test Data	15
Value-Added Options	16
Standard Parts Summary	18

How to Use This Guide

For those who are unfamiliar with EMI shielding honeycomb vent design, it is recommended to first study the Application Design Assistance section, to become familiar with the basic variables associated with EMI shielding vents, their common uses and general limitations.

Those who are already familiar with EMI shielding vent design may simply refer to the appropriate technical data within this document.

Contact Parker Chomerics with any additional design or product information questions. Call Parker Chomerics directly at (781) 935-4850 where an application engineer can assist you or visit chomerics.com for up-to-date catalog information.

What is an EMI Shielding Honeycomb Vent?

A honeycomb vent is either free-standing metallic alloy honeycomb or an assembly incorporating the honeycomb with other value-added features such as framing, plating, gasketing, filters, etc.

These vents are typically incorporated into enclosures where EMI radiation or susceptibility is a concern, as well as where heat dissipation

is necessary to ensure long-term assembly performance.

Application-specific performance can be changed by modifying the size and other associated features of the vent assembly. Design requirements such as, but not limited to, attenuation values, airflow rates and direction, corrosion prevention, durability, air particulate filtration and flame resistance can be achieved.



Application Design Assistance

Many design variables should be considered when developing an EMI shielding honeycomb vent design. Some features are mandatory to ensure correct application performance. Others exclusively offer convenience or improved performance.

Design Variables Summary

The following section is to be used as a brief reference to the variables associated with typical honeycomb vent assembly design. For more in-depth information, please reference the additional information provided as this guide progresses.

Airflow

Airflow performance is inversely proportional to attenuation performance. Infinite metal results in infinite shielding but no airflow, and vice versa.

Three major factors should be considered when determining airflow performance. Listed in order of typical impact on performance are the following:

1. *As cell size decreases, airflow performance decreases.*
2. *As honeycomb thickness increases, greater air turbulence occurs within cells, resulting in decreased airflow.*
3. *Additional layers of value-added features (foam filters, etc.) will decrease airflow.*

Because of the intimate relationship between attenuation and airflow, a careful evaluation and prioritization of technical data is recommended to ensure optimal overall performance of the vent assembly.

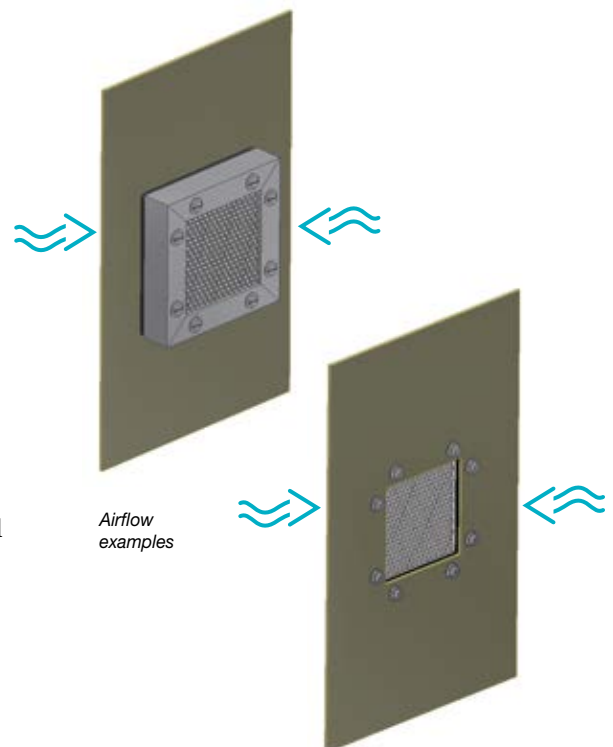

Attenuation

Identifying the EMI shielding requirements for the vent assembly is paramount when beginning a vent design. Depending on this, variables such as material composition and geometry can be determined. Generally speaking, smaller cell size and larger honeycomb thickness results in improved shielding data. Plating can greatly improve shielding performance and is a more common avenue for performance improvement than deviating from standard aluminum honeycomb construction due to cost considerations. For demanding applications, other materials are available.

Installation Methods

Installation methods typically determine requirements for frame robustness and design as well as fastener type and location.

Frames are typically integrated into an EMI honeycomb vent assembly to provide a means of mounting as well as increased structural integrity. Three form factors are available: formed, welded or machined. Versions differentiate from each other in ways that include robustness, foreign object debris performance and price point.

It is recommended that the alloy of the frame match that of the honeycomb in the vent assembly to ensure optimal attenuation and galvanic corrosion performance.

The most common mounting method is to integrate thru-holes into the flange of the frame of the vent assembly, allowing fasteners to pass through the vent and onto the higher level assembly.

Additional methods to affix the vent assembly to the frame are available upon request and include captive fasteners, threaded inserts or no thru-holes for bracketed application assemblies.

Durability

Durability can be improved, as required, to both the frame and honeycomb. Various honeycomb alloys and plating selections can greatly improve durability. Frame durability is typically dictated by geometry, most notably, material thickness.

Aesthetics

For applications where aesthetics or cosmetics are a design consideration, electroless nickel plating or customer-specified paints are common solutions.

Environmental Exposures

The environmental factors the vent will experience during usage can greatly dictate the longevity of vent performance. To assure maximum lifespan, corrosion prevention and particle filtration should be considered.

Galvanic corrosion performance of vent assemblies is controlled by the selection of galvanically similar components that match the metallic content of the mating area of the higher level assembly.

Numerous plating options are available to facilitate improved galvanic compatibility. It should be noted that vent assemblies are not typically plated at the component level, but rather as a full assembly. This makes selective plating design options limited.

Gasketing

Typically, EMI gasketing is necessary to ensure proper electrical grounding between the vent assembly and the interfacing assembly. Gasketing options vary from knit-mesh, beryllium-copper fingerstock to conductive elastomers. Each provides varying degrees of performance across different frequency levels.

Air Filtration

For applications with particle arrestance requirements, various value-added filters can be incorporated into the vent design. The most common media is urethane-based foam, while oil-soaked metal mesh is a more durable option.

Size

Vent footprint (X and Y dimensions) is generally not a manufacturing constraint. For abnormally large dimensions, support brackets should be integrated into the design of the honeycomb area of the vent for added robustness. The Z dimension of the vent assembly is typically constrained by the frame thickness. Numerous standard and custom frame options allow for varying thickness of the overall assembly for applications with clearance concerns.

Flame Exposure

For applications with flammability performance requirements, typical vent designs will pass. Special care is required in selecting gasket and filtration options in these instances.

For applications with flame extinguishment requirements, it is recommended to incorporate Intumescent paint into the design via honeycomb surface coverage.

Foreign Object Debris (FOD)

Traditional vent assembly manufacturing may make vents susceptible to foreign object debris. For applications with sensitivity to FOD, Parker Chomerics has leveraged 50+ years of design experience to create a number of design options to minimize FOD. Foreign object debris requirements should be addressed early in the design cycle to ensure all features of the assembly are taken into consideration.

Honeycomb Summary

When selecting honeycomb, three critical performance variables should be evaluated: material composition, airflow and attenuation.

Material Composition

Standard Chomerics offerings are aluminum, brass, stainless steel and steel. Custom materials are available upon request. The following parameters should be evaluated during the material selection process:

Durability

Steel, stainless steel and brass are the most durable offerings, with aluminum being significantly less durable. Plating, discussed in depth later, can improve durability.

Weight

Aluminum is the lightest material offered, with steel, stainless steel and brass being relatively similar to each other but significantly heavier than aluminum.

Galvanic Compatibility

Though each application has specific corrosion variables, typically brass and stainless steel are utilized in high stress environments. Plating or non-conductive surface coatings can improve corrosion resistance for all honeycomb types.

Shielding Performance

Chomerics standard honeycomb material offerings have different electrical performance, due to both inherent base material properties as well as the differing manufacturing processes used during honeycomb creation. This results in different EMI shielding performance. Rank order shielding performance by material is typically brass, aluminum, steel and stainless steel. Plating can improve honeycomb shielding



performance. Rank order shielding performance by plating option is typically nickel, tin, tin-lead and zinc. Shielding performance is discussed later in this guide during the cell size and thickness selection process. It should be noted the shielding performance over various frequencies differs greatly from material to material.

Price Premium

Aluminum, being the most common material utilized, is the most affordable. The typical price impacts of the other standard materials, in rank order, are steel, stainless steel and brass.

Airflow & Attenuation

Airflow and attenuation are inversely proportional. Infinitely large honeycomb cells result in infinitely small attenuation (and vice versa). Typically, as a design baseline, airflow performance requirements are calculated to meet thermal performance needs for the assembly that the vent is to be installed onto. Once airflow is determined, attenuation and other requirements can be evaluated. Standard cell sizes for honeycomb are 1/16", 1/8" and 1/4", with 1/8" being most common. Standard thicknesses are 1/4", 1/2" and 1", with 1/4" being most common. Custom cell sizes and thicknesses are limited, but available upon request.

See airflow data (page 15) to aid in the design requirements selection process.

Specific attenuation requirements can be met through either plated or unplated alloys. As might be expected, plating adds cost to the vent.

In aluminum honeycomb, a common alternative to plating to improve shielding performance with less of a price impact is to incorporate an additional layer of honeycomb into the design. This second layer of honeycomb is oriented 90 degrees to the first layer to eliminate polarity susceptibility associated with single-layer aluminum honeycomb.

This polarity is associated with seam leakage caused by the non-conductive bonds from cell to cell created during the manufacturing process of adhering aluminum ribbons together to make the honeycomb. By rotating the second layer of honeycomb 90 degrees, RF wave interaction in both the X and Y axes are combated by the seam orientation of each layer of honeycomb.

It should be noted that steel, stainless steel and brass honeycomb versions do not have this non-conductive seam and therefore are not considered candidates for double-layer solutions. It should also be noted that additional space is necessary in the Z-axis of the application to accommodate additional vent size. The Chomerics trade name for this double-layer solution is OMNI-Cell.

Honeycomb Technical Specifications

Table 1 provides a general guideline for honeycomb material selection.

Honeycomb Media Design Selection	Attenuation					Robustness		Corrosion Resistance				Cost			
	Good	Better	Best	Highest	Low Freq. (Magnetic)	Low	High	Good	Better	Best	Highest	Low	Medium	High	Highest
Aluminum - Single Layer - Unplated	X					X		X				X			
Aluminum - Omni Cell (2 layer) - Unplated		X				X		X				X			
Aluminum - Single Layer - Tin Plated			X			X			X				X		
Aluminum - Single Layer - E. Nickel Plated				X		X				X				X	
Brass - Unplated				X			X			X					X
Brass - Plated				X			X			X					X
Steel - Plated				X	X		X		X						X
Stainless Steel		X					X				X				X

Aluminum Honeycomb Selections

- Aluminum Alloy 5052, Grade B, per AMS-C-7438 (straight cell)
- Aluminum Alloy 5052, Grade B, commercial grade (angled cell)

Aluminum Straight Cell Honeycomb Selections		
Cell Size (in.)	Thickness (in.)	Foil Thk. (in.)
1/16 (0.063)	1/8 (0.125)	0.0015 or 0.002
1/8 (0.125)	1/8 (0.125)	0.0015 or 0.002
1/8 (0.125)	1/4 (0.250)	0.0015 or 0.002
1/8 (0.125)	3/8 (0.375)	0.0015 or 0.002
1/8 (0.125)	1/2 (0.500)	0.0015 or 0.002
1/8 (0.125)	5/8 (0.625)	0.0015 or 0.002
1/8 (0.125)	3/4 (0.750)	0.0015 or 0.002
1/8 (0.125)	1.000	0.0015 or 0.002

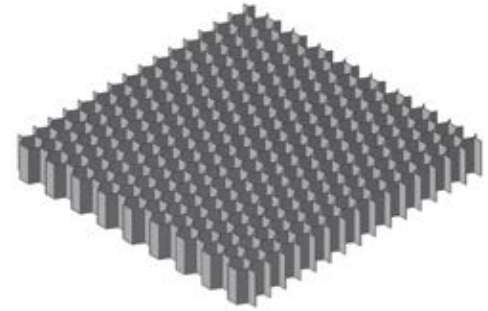
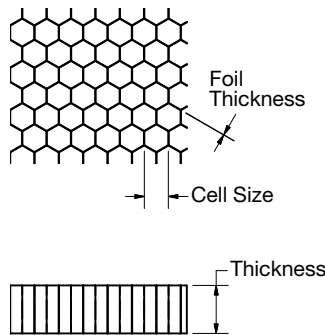

* 1/8 x 1/4 shown

Request information regarding availability of other cell sizes and thicknesses.

Rows highlighted in dark yellow are standards.

* All honeycomb follows this

Angled Honeycomb

Angle Options
30°
45°
60°

- Angled honeycomb can be used to:
 - Provide drip resistance for moisture
 - Direct air flow
 - Create interference with line of sight
- Can be used on its own in a single layer design, or as one of the layers in an omni cell design
- Angles only offered with aluminum honeycomb
- No deviations from available listed above

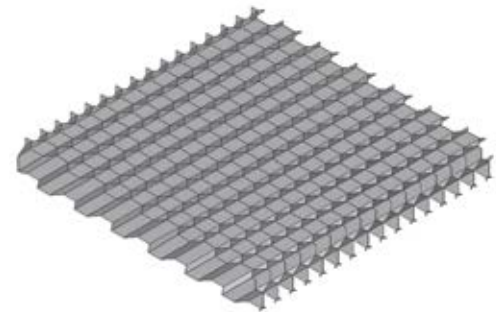
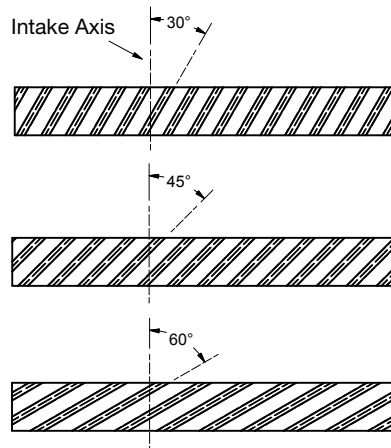

* 1/8 x 1/4 x 45° shown

Brass Honeycomb Selections

- Material: Copper Alloy 260, 1/2 Hard

Brass Honeycomb Selections		
Cell Size (in.)	Thickness (in.)	Foil Thk. (in.)
1/8 (0.125)	3/8 (0.375)	0.005
1/8 (0.125)	1/2 (0.500)	0.005

Request information regarding availability of other cell sizes and thicknesses.

Row highlighted in dark yellow is standard.

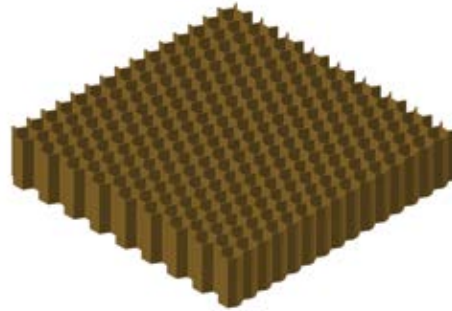

Steel Honeycomb Selections

- Material: 1010 Steel

Steel Honeycomb Selections		
Cell Size (in.)	Thickness (in.)	Foil Thk. (in.)
1/8 (0.125)	3/8 (0.375)	0.005
1/8 (0.125)	1/2 (0.500)	0.005

Request information regarding availability of other cell sizes and thicknesses.

Row highlighted in dark yellow is standard.

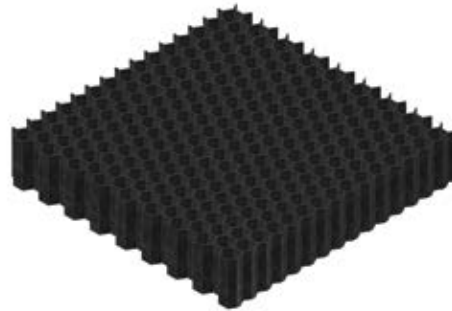

Stainless Steel Honeycomb Selections

- Material: Type 304 Stainless Steel

Stainless Steel Honeycomb Selections		
Cell Size (in.)	Thickness (in.)	Foil Thk. (in.)
1/8 (0.125)	3/8 (0.375)	0.003 or 0.005
1/8 (0.125)	1/2 (0.500)	0.003 or 0.005

Request information regarding availability of other cell sizes and thicknesses.

Row highlighted in dark yellow is standard.

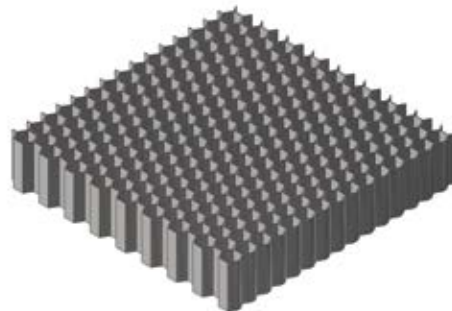

Frames

Frames are typically incorporated in honeycomb vent solutions to provide additional durability and an entity to fasten the honeycomb to the application. Historically, two types of frame designs have been offered: formed and machined. In recent years, with improvements in manufacturing capabilities, formed frame designs have been significantly broadened.

Formed

Historically, the Chomerics FPCV design has been the industry standard for economically framed honeycomb solutions. This design incorporates a stamped frame with fingers on the backside of the assembly. After frame creation and honeycomb incorporation, these fingers are folded over to ensure efficient electrical contact between the frame and the honeycomb as well as to hold the honeycomb in place. Typically these frames are made from .032" thick stock and are aluminum in composition.

In more recent years, recognizing the need for increased durability, foreign object debris-free (FOD-free) framed honeycomb solutions, Chomerics created the FPMV design. Two major differences of the FPMV design are frame stock thickness (.070") and fully wrapped framing (rather than fingers). Both of these features significantly increase the durability of the honeycomb assembly, while continuing to eliminate FOD concerns without affecting shielding or airflow performance.

For both FPCV and FPMV designs, thru-holes, slots and other features can be incorporated into the design to accommodate application-specific requirements. In addition, in most situations, inserts or other fastener types can be incorporated to aid in product installation ease.

In both designs, aluminum is standard, but alternative materials can be evaluated on a case-by-case basis.

Machined and Extruded

Machined and extruded frames have long been the industry standard for robust framing. This design incorporates various metal channel extrusions, cut to length, installed around the honeycomb media and then welded at one or more of the corners. Numerous standard extrusion profiles are offered to meet various design requirements.

Because of secondary drilling operations to incorporate thru-holes into the frame design, FOD can be problematic with these designs in applications requiring a FOD-free solution. Besides the aforementioned formed FPMV design, various alternatives have been created for machined frames.

Bushings

Hollow bushings are incorporated at thru-hole locations to ensure that remnant debris from the drilling process is retained within the frame or eliminated altogether.

Solid Framing

A typical channel with a thicker land area around the perimeter of the installed frame. That land area is then drilled-through and cleaned thoroughly. Without breaching the channel area of the extrusion during the drilling process, FOD is eliminated.

In all machined frame designs, aluminum is standard. Steel, stainless steel and brass framing can be evaluated on a case-by-case basis for applications requiring galvanic similarity between the honeycomb media and the framing.

Frameless

In some instances, customers do not require framing for their honeycomb vent solution. In those instances, Chomerics can convert and supply honeycomb in various size and shape requirements.

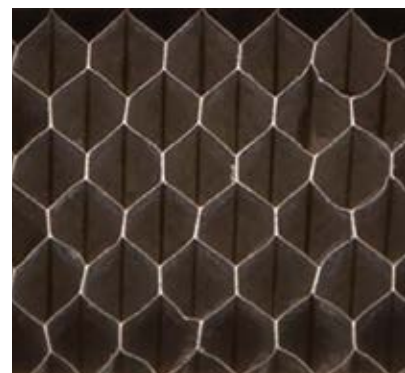

Formed Frames

- Material: Aluminum Alloy 5052-H32 per AMS-QQ-A-250/8

Frame without honeycomb media

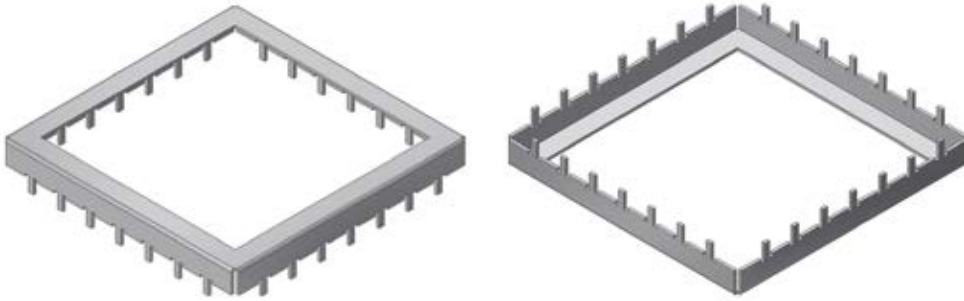

Frame with honeycomb media encapsulated

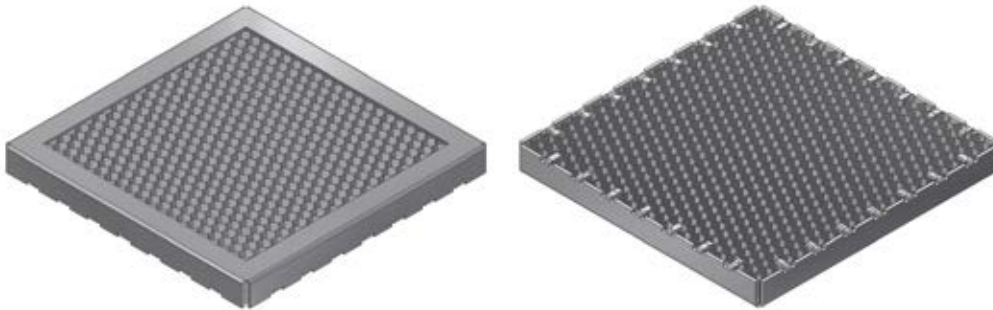

FMPV – without honeycomb media (left), with media (right)

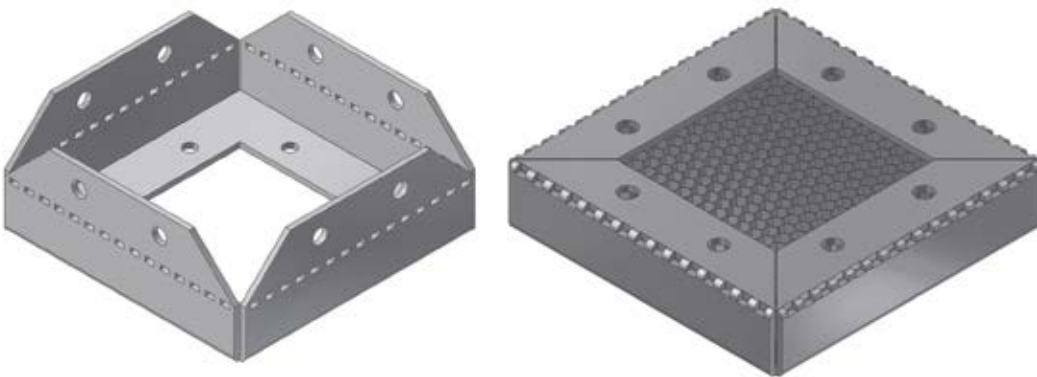

Aluminum Extrusion Selections

- Material: Aluminum Alloy 6063-T1, T4, or T6 per ASTM B221
- Dimensions below are inches

Standard C-Channel Extrusion Style Selections

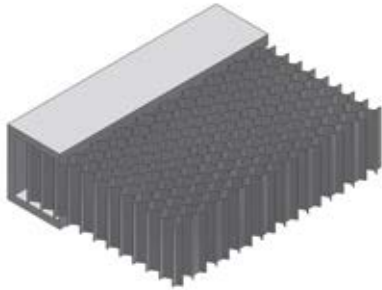

Fits total honeycomb thickness of 1/4 (0.250)

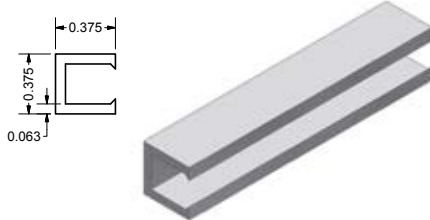

Fits total honeycomb thickness of 3/8 (0.375)

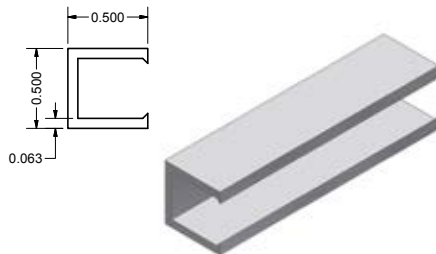

Fits total honeycomb thickness of 1/2 (0.500)

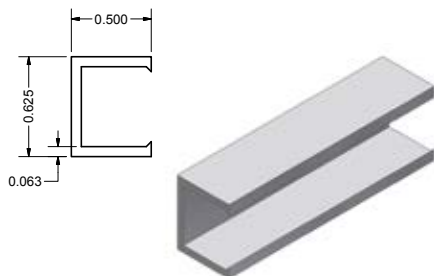

Standard Chair Extrusion Style Selections

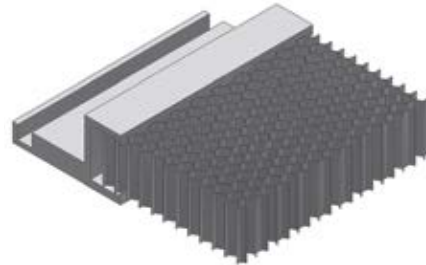

Fits total honeycomb thickness of 1/4 (0.250)

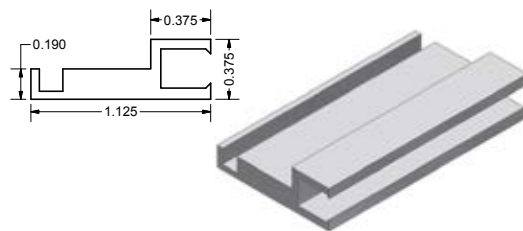

Fits total honeycomb thickness of 3/8 (0.375)

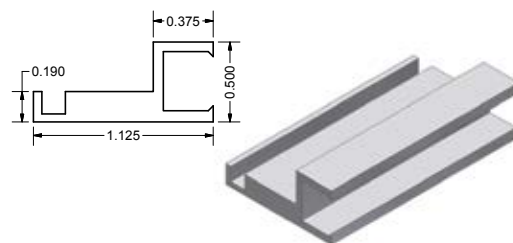

Fits total honeycomb thickness of 1/2 (0.500)

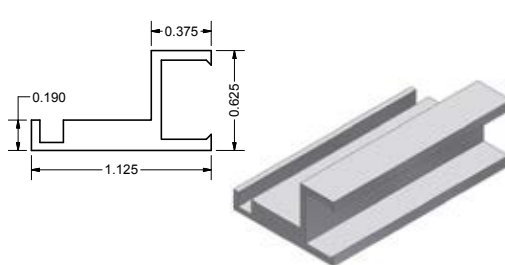

Other extrusion styles are available. Please contact Parker Chomerics to discuss other design options.

Plating

Plating is not a requirement for honeycomb vent assemblies. It is typically recommended for applications requiring improvements to one or more of the following characteristics: durability, corrosion resistance or shielding performance. Standard Chomerics plating offerings include, but are not limited to, nickel, tin and tin-lead. Typically, framing and honeycomb are plated in unison to ensure optimal product performance.

Durability

Normally associated with aluminum honeycomb solutions, i.e. nickel, is the most commonly recommended plating for durability improvement.

Corrosion Resistance

Parameters regarding galvanic corrosion are highly custom unique for each application. Base material, mating material and gasketing are a few of the variables that should be evaluated during the plating selection process.

Shielding Performance

As a general rule, the more electrically conductive the base plating material is, the higher the shielding performance.

As an alternative to tin-plating, Chomerics recommends and offers ECOPLATE. ECOPLATE is a Chomerics-developed flame-sputtered tin coating that mechanically bonds to the honeycomb to which it is applied. Both cost and shielding performance are improved upon by utilizing ECOPLATE as compared to tin-plating.

ECOPLATE is a non-hazardous material, allowing for easy disposal of product in situations where typically controlled waste disposal would be necessary with tin-plated parts.

Typically ECOPLATED honeycomb solutions only have the honeycomb media coated, although entire product coverage is available upon request.



Example of honeycomb vent shown.



Chomerics integrated chemical conversion coating (chem-film) manufacturing line.

Selection Guidelines

- **Table 2** details common plating options and the applicable specification.

Plating and Finish Options	
Plating/Finish	Spec.
Chem-Film (Standard)	MIL-DTL-5541, Type I, Class 3
Chem-Film	MIL-DTL-5541, Type I, Class 1A
Chem-Film (RoHS Compliant)	Trivalent Chromate, MIL-DTL-5541, Type II, Class 3, Color Clear/Colorless
Tin Plating	ASTM B545, Minimum Thickness to be Specified
Electroless Nickel	AMS 2404, CLASS 1, Minimum Thickness to be Specified
Tin-Lead	90/10, ASTM B579, Minimum Thickness to be Specified

- **Table 3** provides a general guideline for plating selection and cost based on honeycomb design.

Common Plating Selections on Vent Material Options					
Plating/Finish	Material				
	Aluminum Single Layer Honeycomb	Aluminum Omni Cell	Brass	Steel	Stainless Steel
Chem-Film (Standard)	\$	\$			
Chem-Film (Class 1A)	\$	\$			
Chem-Film (RoHS Compliant)	\$	\$			
Tin Plating	\$\$		\$\$	\$\$	
Electroless Nickel	\$\$\$			\$\$\$	
Tin-Lead			\$\$\$		
None					\$

\$ = Most economical

\$\$ = More costly

\$\$\$ = Most costly

Common Gasket Options

C-Channel

C-Channel frame with combo gasket

Gasket materials:

- Neoprene sponge per ASTM D6576, Grade A, Type 2, Cond. Medium
- Monel Mesh per QQ-N-281 or Aluminum Mesh per AMS-4182
- PSA mounted

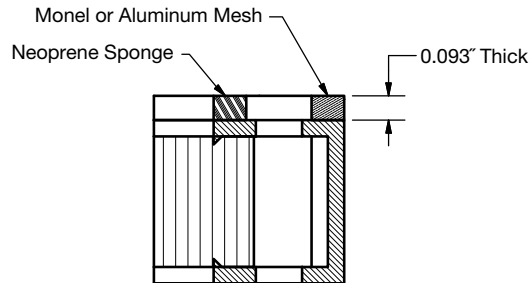
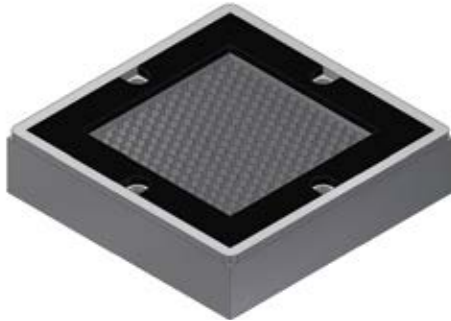

C-Channel Frame with Cho-Seal, conductive elastomer

Gasket materials:

- Any type of Cho-Seal material that can be extruded or die-cut from a sheet
- PSA mounted on frame. Other mounting options available

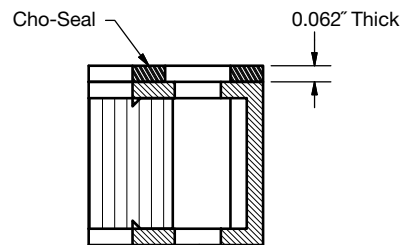
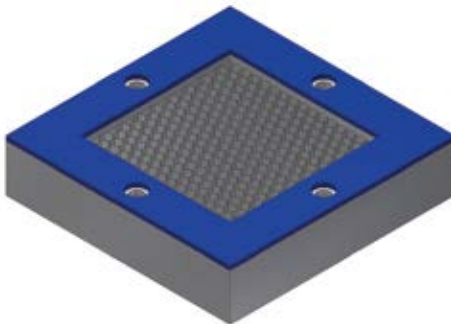

Chair Extrusions

Chair extrusion frame with mesh gasket in groove

Gasket materials:

- Monel per QQ-N-281, or
- Aluminum per AMS 4182
- Friction fit and/or mounted with spot bonds

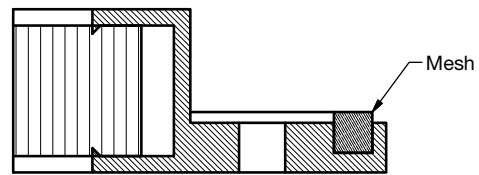
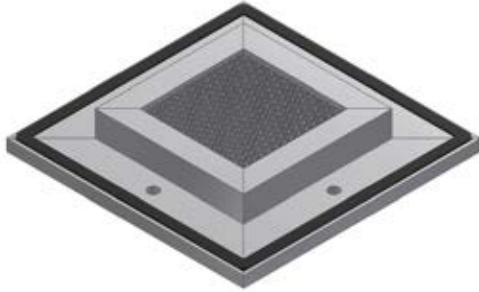

Chair extrusion frame with Cho-Seal gasket in groove

Gasket materials:

- Any type of Cho-Seal material that can be extruded
- Hollow-O or solid cross section
- Friction fit and/or mounted with spot bonds

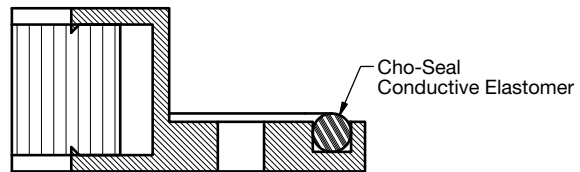
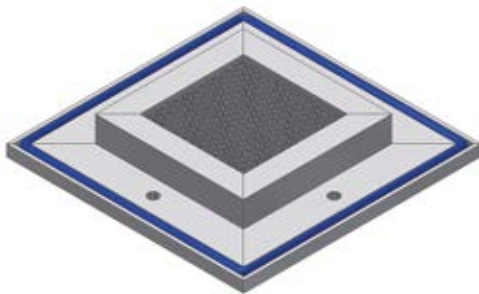

Chair Extrusions (continued)

Chair extrusion frame with combo gasket

Gasket materials:

- Neoprene sponge per ASTM D6576, Grade A, Type 2, Cond. Medium
- Monel mesh per QQ-N-281 or aluminum mesh per AMS-4182
- PSA mounted

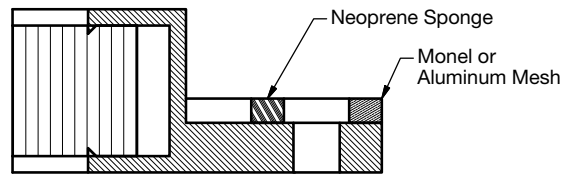
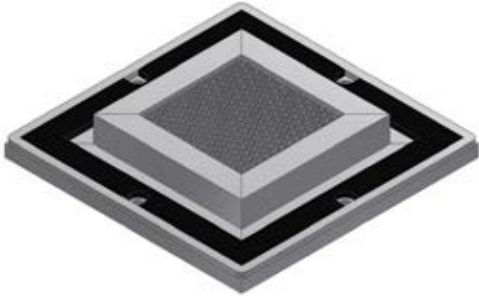

Chair extrusion frame with Cho-Seal gasket

Gasket materials:

- Any type of Cho-Seal material that can be extruded or die-cut from a sheet
- PSA mounted on frame. Other mounting options available

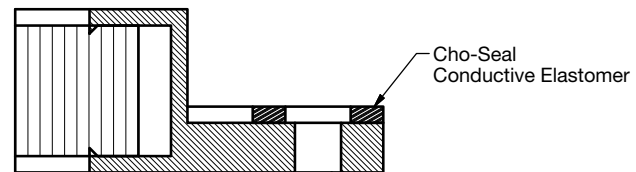
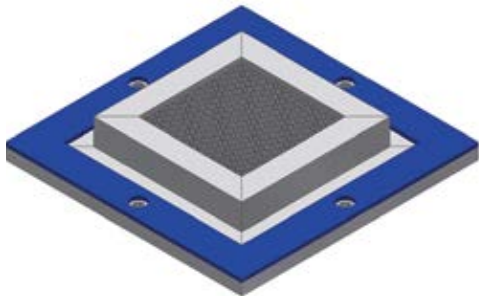

Honeycomb Performance Test Data

Shielding

Aluminum

Chem-Film Finish

Single Layer, 1/8" cell x 1/2" thk. Honeycomb

Frequency	Attenuation Horizontal	Attenuation Vertical
100 MHz	70 dB	25 dB
500 MHz	50 dB	35 dB
1 GHz	45 dB	35 dB
5 GHz	50 dB	35 dB
10 GHz	55 dB	40 dB

Chem-Film Finish

2 Layer Omni Cell, 1/8" cell x 1/4" thk. Honeycomb, each layer

Frequency	Attenuation Horizontal	Attenuation Vertical
100 MHz	60 dB	60 dB
500 MHz	50 dB	55 dB
1 GHz	50 dB	50 dB
5 GHz	45 dB	50 dB
10 GHz	50 dB	50 dB

Electroless Nickel Plating

Single Layer, 1/8" cell x 1/2" thk. Honeycomb

Frequency	Attenuation Horizontal	Attenuation Vertical
100 MHz	95 dB	90 dB
500 MHz	85 dB	80 dB
1 GHz	80 dB	85 dB
5 GHz	85 dB	85 dB
10 GHz	80 dB	85 dB

Steel

Electroless Nickel Plating

Single Layer, 1/8" cell x 1/2" thk. Honeycomb

Frequency	Attenuation H-Field	Attenuation E-Field
10 kHz	35 dB	-
200 kHz	60 dB	-
100 MHz	-	100 dB
500 MHz	-	90 dB
1 GHz	-	85 dB
5 GHz	-	80 dB
10 GHz	-	80 dB

Brass

Tin Lead Plating

Single Layer, 1/8" cell x 1/2" thk. Honeycomb

Frequency	Attenuation
100 MHz	95 dB
500 MHz	85 dB
1 GHz	80 dB
5 GHz	85 dB
10 GHz	80 dB

Air Flow

Aluminum

A = 1/8" cell x 1/2" thk. B = 1/8" cell x 1/4" thk.

Air Speed (ft./min.)	Pressure Drop (in. H ₂ O)	
	A	B
250	0.02	<0.02
500	0.04	0.03
1000	0.07	0.05
2000	0.13	0.09
3000	0.20	0.16
4000	0.28	0.23

Brass, Steel, Stainless Steel

A = 1/8" cell x 1/2" thk. B = 1/8" cell x 1/4" thk.

Air Speed (ft./min.)	Pressure Drop (in. H ₂ O)	
	A	B
250	0.02	<0.02
500	0.08	0.06
1000	0.14	0.10
2000	0.26	0.18
3000	0.40	0.32
4000	0.56	0.46

Test data is for guideline only and may differ depending on a variety of factors. Please contact Parker Chomerics for more detailed information.

Value-Added Options

Additional Shielding

For added shielding performance, Parker offers a Cho-Bond 360-20 bead around the honeycomb/frame interface. This is typically added to an aluminum honeycomb vent that has electroless nickel plating.

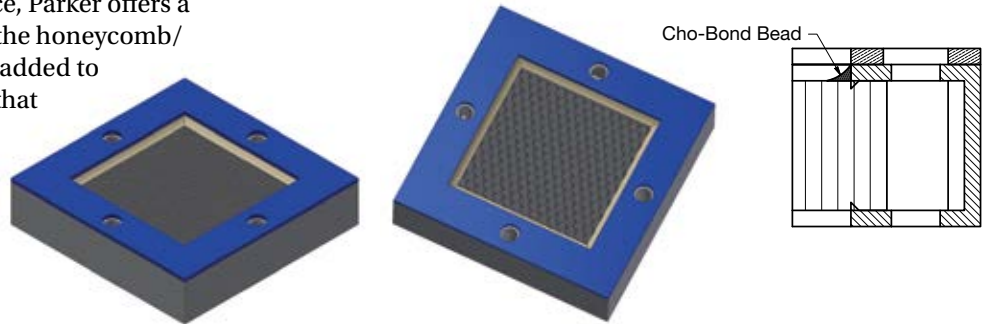

Physical Protection

In applications where aluminum honeycomb may be at risk of damage by being struck by an object, Parker offers an aluminum protective diamond grill.

Use of the protective grill will sacrifice some air flow performance and possibly require a change in frame dimensions.



Custom Machined Framed Vents

For applications where the mating chassis may not be a typical rectangle or square, or is not easily modifiable, Parker can provide a frame shaped to the specific chassis. An example of this is a circular framed vent, shown at right. This would allow a circular mating chassis to remain circular, avoiding any need for modification.



Customer Specified Inserts

Because mounting configuration can vary by application, Parker can offer various types of inserts at the mounting hole locations to align with a specific mounting configuration. Shown here are two common options:

Clinch fasteners, standoffs



Frame only with fasteners

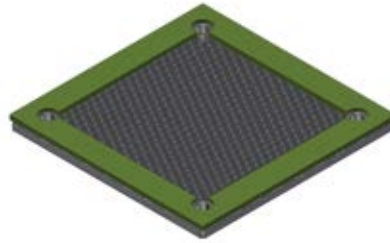

Frame with gasket and honeycomb

Threaded inserts, rivet nuts

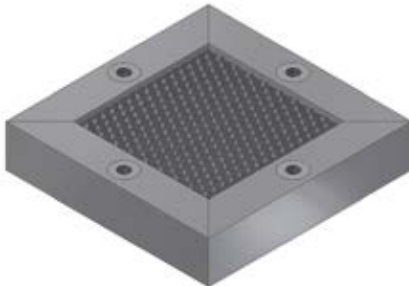

Shown without a gasket, for clarity

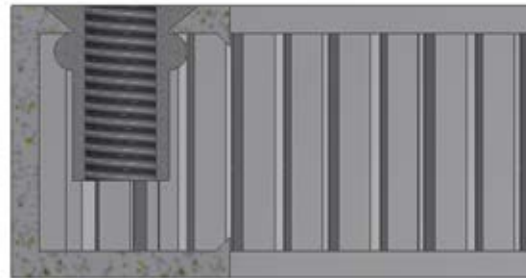

Cross sectional view

Customer Specified Paint Colors

If an application requires the exposed surfaces of the vent to match the chassis color, Parker can offer customer specified paint on the frame and honeycomb. One example of this is a CARC paint with a specified color chip. This paint can also offer chemical resistance. Note that the gasket mating surface on the vent is typically masked from the paint.

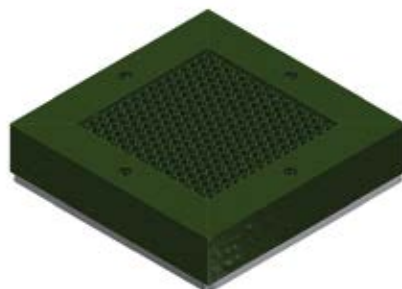
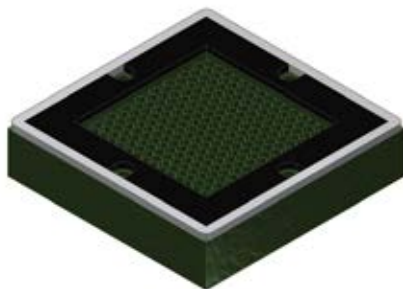

Standard Parts Summary

Common Honeycomb Vent Products

Table 4 See drawing below for A, B, C, D references

Common Honeycomb Vent Products								
Part Number			Footprint, inch (mm)		Side A Dimensions, inch (mm)			
Shield Cell	Omni Cell	Shieldscreen	A	B	C	# of Fasteners	Spacing	
06-0302-0111	06-1102-0872	06-1302-0896	4 (101.6)	4 (101.6)	1.750 (44.45)	1	-	
06-0302-0112	06-1102-0873	06-1302-0897	4 (101.6)	6 (152.4)	1.750 (44.45)	1	-	
06-0302-0113	06-1102-0874	06-1302-0898	4 (101.6)	8 (203.2)	1.750 (44.45)	1	-	
06-0302-0114	06-1102-0875	06-1302-0899	4 (101.6)	12 (304.8)	1.750 (44.45)	1	-	
06-0302-0108	06-1102-0876	06-1302-0900	5 (127.0)	5 (127.0)	2.250 (57.15)	1	-	
06-0302-0115	06-1102-0877	06-1302-0901	5 (127.0)	7 (177.8)	2.250 (57.15)	1	-	
06-0302-0116	06-1102-0878	06-1302-0902	5 (127.0)	10 (254.0)	2.250 (57.15)	1	-	
06-0302-0117	06-1102-0879	06-1302-0903	6 (152.4)	6 (152.4)	1.000 (25.40)	2	3.500 (88.90)	
06-0302-0118	06-1102-0880	06-1302-0904	6 (152.4)	8 (203.2)	1.250 (31.75)	2	3.000 (76.20)	
06-0302-0119	06-1102-0881	06-1302-0905	6 (152.4)	12 (304.8)	1.000 (25.40)	2	3.500 (88.90)	
06-0302-0120	06-1102-0882	06-1302-0906	6 (152.4)	18 (457.2)	1.000 (25.40)	2	3.500 (88.90)	
06-0302-0121	06-1102-0883	06-1302-0907	7 (177.8)	7 (177.8)	1.500 (38.10)	2	3.500 (88.90)	
06-0302-0122	06-1102-0884	06-1302-0908	7 (177.8)	10 (254.0)	1.500 (38.10)	2	3.500 (88.90)	
06-0302-0123	06-1102-0885	06-1302-0909	7 (177.8)	14 (355.6)	1.500 (38.10)	2	3.500 (88.90)	
06-0302-0124	06-1102-0886	06-1302-0910	8 (203.2)	8 (203.2)	2.000 (50.80)	2	3.500 (88.90)	
06-0302-0125	06-1102-0887	06-1302-0911	8 (203.2)	12 (304.8)	0.750 (19.05)	3	3.000 (76.20)	
06-0302-0126	06-1102-0888	06-1302-0912	8 (203.2)	16 (406.4)	0.750 (19.05)	3	3.000 (76.20)	
06-0302-0109	06-1102-0889	06-1302-0913	10 (254.0)	10 (254.0)	1.250 (31.75)	3	3.500 (88.90)	
06-0302-0127	06-1102-0890	06-1302-0914	10 (254.0)	14 (355.6)	1.250 (31.75)	3	3.500 (88.90)	
06-0302-0128	06-1102-0891	06-1302-0915	10 (254.0)	18 (457.2)	1.250 (31.75)	3	3.500 (88.90)	
06-0302-0129	06-1102-0892	06-1302-0916	12 (304.8)	12 (304.8)	1.250 (31.75)	4	3.000 (76.20)	
06-0302-0110	06-1102-0893	06-1302-0917	12 (304.8)	16 (406.4)	1.250 (31.75)	4	3.000 (76.20)	
06-0302-0083	06-1102-0894	06-1302-0918	12 (304.8)	20 (508.0)	1.250 (31.75)	4	3.000 (76.20)	
06-0302-0130	06-1102-0895	06-1302-0919	12 (304.8)	24 (609.6)	1.250 (31.75)	4	3.000 (76.20)	

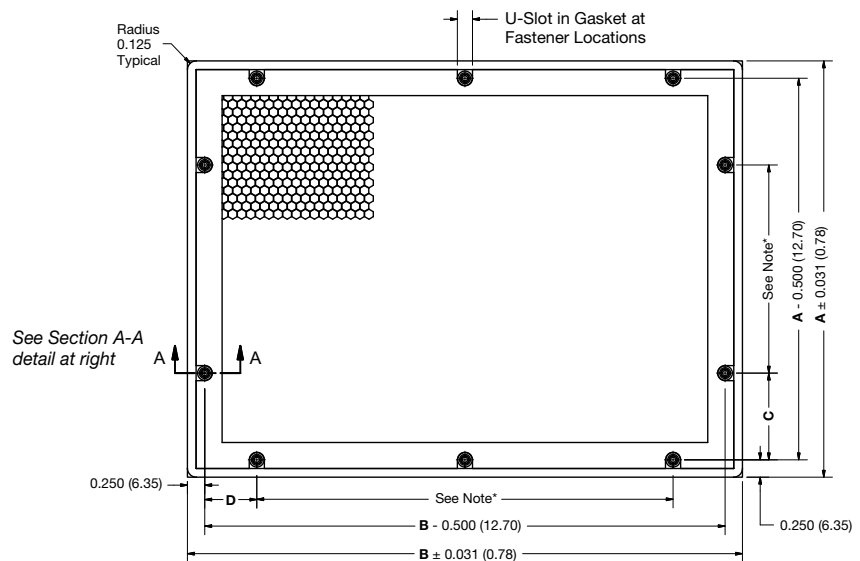

* Tolerances on home fastener locations $\pm 0.015 (0.38)$
Tolerances apply up to 24.00 (609.6)

Side B Dimensions, inch (mm)				
D	# of Fasteners	Spacing	Effective Area in ² (cm ²)	
1.750 (44.45)	1	-	9 (58)	
1.000 (25.40)	2	3.500 (88.90)	15 (97)	
0.750 (19.05)	3	3.000 (76.20)	21 (135)	
1.250 (31.75)	4	3.000 (76.20)	33 (213)	
0.750 (19.05)	2	3.000 (76.20)	16 (103)	
1.500 (38.10)	2	3.500 (88.90)	24 (155)	
1.250 (31.75)	3	3.500 (88.90)	36 (232)	
1.000 (25.40)	2	3.500 (88.90)	25 (161)	
0.750 (19.05)	3	3.000 (76.20)	35 (226)	
1.250 (31.75)	4	3.000 (76.20)	55 (355)	
1.250 (31.75)	5	3.750 (95.25)	85 (548)	
1.500 (38.10)	2	3.500 (88.90)	36 (232)	
1.250 (31.75)	3	3.500 (88.90)	54 (348)	
1.500 (38.10)	4	3.500 (88.90)	78 (503)	
0.750 (19.05)	3	3.000 (76.20)	49 (316)	
1.250 (31.75)	4	3.000 (76.20)	77 (497)	
1.250 (31.75)	5	3.250 (82.55)	105 (677)	
1.250 (31.75)	3	3.500 (88.90)	81 (522)	
1.500 (38.10)	4	3.500 (88.90)	117 (755)	
1.250 (31.75)	5	3.750 (95.25)	153 (987)	
1.250 (31.75)	4	3.000 (76.20)	121 (780)	
1.250 (31.75)	5	3.250 (82.55)	165 (1064)	
1.000 (25.40)	6	3.500 (88.90)	209 (1348)	
1.250 (31.75)	7	3.500 (88.90)	253 (1632)	

Section A-A of drawing at left

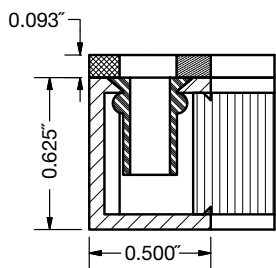

Single Layer

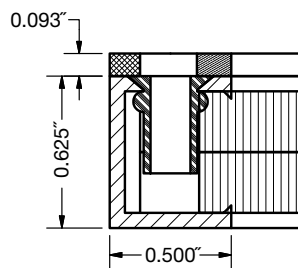

Omni Cell

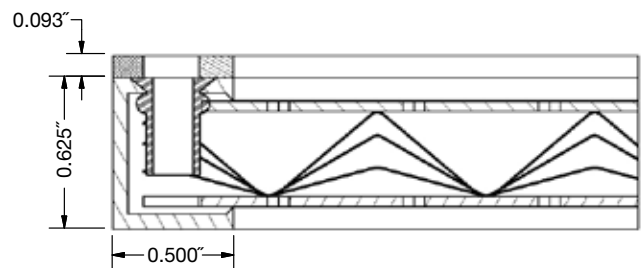

Shieldscreen

Streamshield™ Vent Panels

Ordering Procedure

Use the following part number system to order Streamshield vent panels. For alternative frame and honeycomb cell sizes or additional customization, part numbers will be assigned by Parker Chomerics.

Table 5

Streamshield Vents for Standard Fan Sizes							Part Numbers	
Fan Size	Dimensions, inch (mm)						Config. 1	Config 2.
	A	B	C	D	E (dia.)	F (dia.)		
25 mm	0.79 (20.00)	NA	NA	1.38 (35.05)	0.90 (22.86)	0.117 (2.97)	—	11025
40 mm	1.26 (25.28)	1.58 (40.13)	1.18 (29.97)	1.96 (49.78)	1.50 (38.10)	0.147 (3.73)	10040	11040
60 mm	1.97 (50.04)	2.29 (58.17)	1.79 (45.47)	2.47 (62.74)	2.05 (52.07)	0.147 (3.73)	10060	11060
80 mm	2.81 (71.37)	3.13 (79.50)	2.63 (66.80)	3.51 (89.15)	3.00 (76.20)	0.172 (4.37)	10080	11080
92 mm	3.25 (82.55)	3.57 (90.68)	3.07 (77.98)	3.95 (100.33)	3.40 (86.36)	0.172 (4.37)	10092	11092
120 mm	4.13 (104.90)	4.45 (113.03)	3.95 (100.33)	4.83 (122.68)	4.20 (106.68)	0.172 (4.37)	10120	11120
150 mm	6.38 (162.05)	6.70 (170.18)	6.20 (157.48)	6.70 (170.18)	5.40 (137.16)	0.172 (4.37)	10150	11150

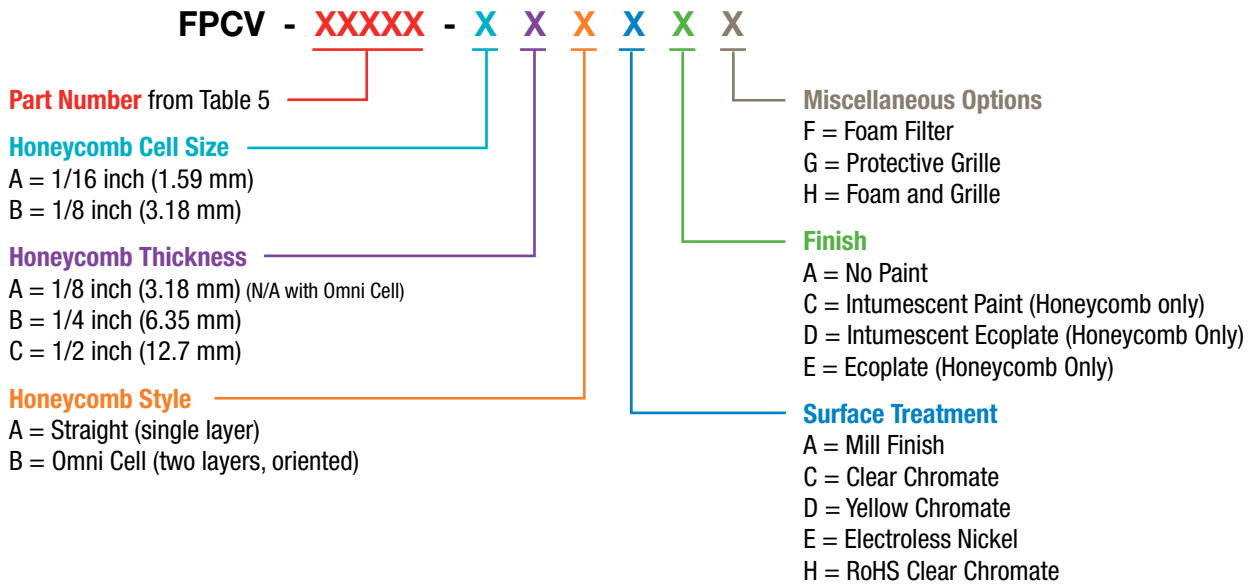

Standard Streamshield Configurations

(All FPCV vent configurations are supplied with EMI fabric over foam gaskets, not shown.)

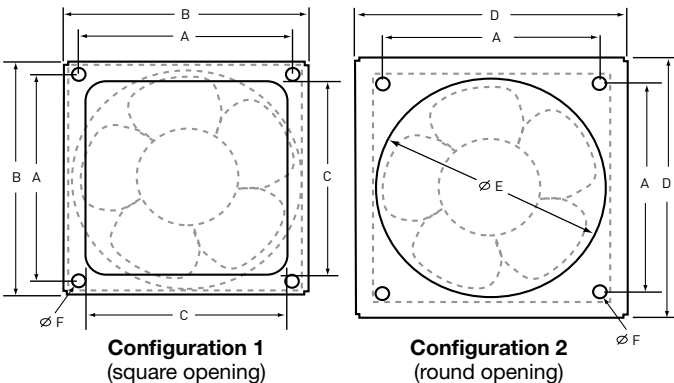

Offer of Sale

PARKER-HANNIFIN CORPORATION OFFER OF SALE

1. **Definitions.** As used herein, the following terms have the meanings indicated.

- Buyer:** means any customer receiving a Quote for Products from Seller.
Goods: means any tangible part, system or component to be supplied by the Seller.
Products: means the Goods, Services and/or Software as described in a Quote provided by the Seller.
Quote: means the offer or proposal made by Seller to Buyer for the supply of Products.
Seller: means Parker-Hannifin Corporation, including all divisions and businesses thereof.
Services: means any services to be supplied by the Seller.
Software: means any software related to the Products, whether embedded or separately downloaded.
Terms: means the terms and conditions of this Offer of Sale or any newer version of the same as published by Seller electronically at www.parker.com/saleterms.

2. **Terms.** All sales of Products by Seller are contingent upon, and will be governed by, these Terms and, these Terms are incorporated into any Quote provided by Seller to any Buyer. Buyer's order for any Products whether communicated to Seller verbally, in writing, by electronic data interface or other electronic commerce, shall constitute acceptance of these Terms. Seller objects to any contrary or additional terms or conditions of Buyer. Reference in Seller's order acknowledgement to Buyer's purchase order or purchase order number shall in no way constitute an acceptance of any of Buyer's terms of purchase. No modification to these Terms will be binding on Seller unless agreed to in writing and signed by an authorized representative of Seller.

3. **Price; Payment.** The Products set forth in Seller's Quote are offered for sale at the prices indicated in Seller's Quote. Unless otherwise specifically stated in Seller's Quote, prices are valid for thirty (30) days and do not include any sales, use, or other taxes or duties. Seller reserves the right to modify prices at any time to adjust for any raw material price fluctuations. Unless otherwise specified by Seller, all prices are F.C.A. Seller's facility (INCOTERMS 2010). All sales are contingent upon credit approval and payment for all purchases is due thirty (30) days from the date of invoice (or such date as may be specified in the Quote). Unpaid invoices beyond the specified payment date incur interest at the rate of 1.5% per month or the maximum allowable rate under applicable law.

4. **Shipment; Delivery; Title and Risk of Loss.** All delivery dates are approximate. Seller is not responsible for damages resulting from any delay. Regardless of the manner of shipment, delivery occurs and title and risk of loss or damage pass to Buyer, upon placement of the Products with the shipment carrier at Seller's facility. Unless otherwise agreed, Seller may exercise its judgment in choosing the carrier and means of delivery. No deferral of shipment at Buyers' request beyond the respective indicated shipping date will be made except on terms that will indemnify, defend and hold Seller harmless against all loss and additional expense. Buyer shall be responsible for any additional shipping charges incurred by Seller due to Buyer's acts or omissions.

5. **Warranty.** The warranty related to the Products is as follows: (i) Goods are warranted against defects in material or workmanship for a period of twelve (12) months from the date of delivery or 2,000 hours of use, whichever occurs first; (ii) Services shall be performed in accordance with generally accepted practices and using the degree of care and skill that is ordinarily exercised and customary in the field to which the Services pertain and are warranted for a period of six (6) months from the completion of the Services by Seller; and (iii) Software is only warranted to perform in accordance with applicable specifications provided by Seller to Buyer for ninety (90) days from the date of delivery or, when downloaded by a Buyer or end-user, from the date of the initial download. All prices are based upon the exclusive limited warranty stated above, and upon the following disclaimer:

DISCLAIMER OF WARRANTY: THIS WARRANTY IS THE SOLE AND ENTIRE WARRANTY PERTAINING TO PRODUCTS. SELLER DISCLAIMS ALL OTHER WARRANTIES, EXPRESS AND IMPLIED, INCLUDING DESIGN, NONINFRINGEMENT, MERCHANTABILITY, AND FITNESS FOR A PARTICULAR PURPOSE. SELLER DOES NOT WARRANT THAT THE SOFTWARE IS ERROR-FREE OR FAULT-TOLERANT, OR THAT BUYER'S USE THEREOF WILL BE SECURE OR UNINTERRUPTED. BUYER AGREES AND ACKNOWLEDGES THAT UNLESS OTHERWISE AUTHORIZED IN WRITING BY SELLER THE SOFTWARE SHALL NOT BE USED IN CONNECTION WITH HAZARDOUS OR HIGH RISK ACTIVITIES OR ENVIRONMENTS. EXCEPT AS EXPRESSLY STATED HEREIN, ALL PRODUCTS ARE PROVIDED "AS IS".

6. **Claims; Commencement of Actions.** Buyer shall promptly inspect all Products upon receipt. No claims for shortages will be allowed unless reported to the Seller within ten (10) days of delivery. Buyer shall notify Seller of any alleged breach of warranty within thirty (30) days after the date the non-conformance is or should have been discovered by Buyer. Any claim or action against Seller based upon breach of contract or any other theory, including tort, negligence, or otherwise must be commenced within twelve (12) months from the date of the alleged breach or other alleged event, without regard to the date of discovery.

7. **LIMITATION OF LIABILITY.** IN THE EVENT OF A BREACH OF WARRANTY, SELLER WILL, AT ITS OPTION, REPAIR OR REPLACE THE NON-CONFORMING PRODUCT, RE-PERFORM THE SERVICES, OR REFUND THE PURCHASE PRICE PAID WITHIN A REASONABLE PERIOD OF TIME. **IN NO EVENT IS SELLER LIABLE FOR ANY SPECIAL, INDIRECT, INCIDENTAL OR CONSEQUENTIAL DAMAGES ARISING OUT OF, OR AS THE RESULT OF, THE SALE, DELIVERY, NON-DELIVERY, SERVICING, NON-COMPLETION OF SERVICES, USE, LOSS OF USE OF, OR INABILITY TO USE THE PRODUCTS OR ANY PART THEREOF, LOSS OF DATA, IDENTITY, PRIVACY, OR CONFIDENTIALITY, OR FOR ANY CHARGES OR EXPENSES OF ANY NATURE INCURRED WITHOUT SELLER'S WRITTEN CONSENT, WHETHER BASED IN CONTRACT, TORT OR OTHER LEGAL THEORY. IN NO EVENT SHALL SELLER'S LIABILITY UNDER ANY CLAIM MADE BY BUYER EXCEED THE PURCHASE PRICE PAID FOR THE PRODUCTS.**

8. **Loss to Buyer's Property.** Any designs, tools, patterns, materials, drawings, confidential information or equipment furnished by Buyer or any other items which are or become Buyer's property, will be considered obsolete and may be destroyed by Seller after two (2) consecutive years have elapsed without Buyer ordering the Products manufactured using such property. Seller shall not be responsible for any loss or damage to such property while it is in Seller's possession or control.

9. **Special Tooling.** Special Tooling includes but is not limited to tooling, jigs, fixtures and associated manufacturing equipment acquired or necessary to manufacture Products. A tooling charge may be imposed for any Special Tooling. Such Special Tooling shall be and remain Seller's property notwithstanding payment of any charges by Buyer. In no event will Buyer acquire any interest in Special Tooling belonging to Seller that is utilized in the manufacture of the Products, even if such Special Tooling has been specially converted or adapted for such manufacture and notwithstanding any charges paid by Buyer. Unless otherwise agreed, Seller has the right to alter, discard or otherwise dispose of any Special Tooling or other property in its sole discretion at any time.

10. **Security Interest.** To secure payment of all sums due, Seller retains a security interest in all Products delivered to Buyer and, Buyer's acceptance of these Terms is deemed to be a Security Agreement under the Uniform Commercial Code. Buyer authorizes Seller as its attorney to execute and file on Buyer's behalf all documents Seller deems necessary to perfect its security interest.

11. **User Responsibility.** The Buyer through its own analysis and testing, is solely responsible for making the final selection of the Products and assuring that all performance, endurance, maintenance, safety and warning requirements of the application of the Products are met. The Buyer must analyze all aspects of the application and follow applicable industry standards, specifications, and other technical information

provided with the Product. If Seller provides Product options based upon data or specifications provided by the Buyer, the Buyer is responsible for determining that such data and specifications are suitable and sufficient for all applications and reasonably foreseeable uses of the Products. In the event the Buyer is not the end-user, Buyer will ensure such end-user complies with this paragraph.

12. Use of Products; Indemnity by Buyer. Buyer shall comply with all instructions, guides and specifications provided by Seller with the Products. **Unauthorized Uses.** If Buyer uses or resells the Products for any uses prohibited in Seller's instructions, guides or specifications, or Buyer otherwise fails to comply with Seller's instructions, guides and specifications, Buyer acknowledges that any such use, resale, or non-compliance is at Buyer's sole risk. Buyer shall indemnify, defend, and hold Seller harmless from any losses, claims, liabilities, damages, lawsuits, judgments and costs (including attorney fees and defense costs), whether for personal injury, property damage, intellectual property infringement or any other claim, brought by or incurred by Buyer, Buyer's employees, or any other person, arising out of: (a) improper selection, application, design, specification or other misuse of Products provided by Seller; (b) any act or omission, negligent or otherwise, of Buyer; (c) Seller's use of patterns, tooling, equipment, plans, drawings, designs or specifications or other information or things furnished by Buyer; (d) damage to the Products from an external cause, repair or attempted repair by anyone other than Seller, failure to follow instructions, guides and specifications provided by Seller, use with goods not provided by Seller, or opening, modifying, deconstructing or tampering with the Products for any reason; or (e) Buyer's failure to comply with these Terms. Seller shall not indemnify Buyer under any circumstance except as otherwise provided in these Terms.

13. Cancellations and Changes. Buyer may not cancel or modify any order for any reason, except with Seller's written consent and upon terms that will indemnify, defend and hold Seller harmless against all direct, incidental and consequential loss or damage. Seller, at any time, may change Product features, specifications, designs and availability.

14. Limitation on Assignment. Buyer may not assign its rights or obligations without the prior written consent of Seller.

15. Force Majeure. Seller does not assume the risk and is not liable for delay or failure to perform any of Seller's obligations by reason of events or circumstances beyond its reasonable control ("Events of Force Majeure"). Events of Force Majeure shall include without limitation: accidents, strikes or labor disputes, acts of any government or government agency, acts of nature, delays or failures in delivery from carriers or suppliers, shortages of materials, or any other cause beyond Seller's reasonable control.

16. Waiver and Severability. Failure to enforce any provision of these Terms will not invalidate that provision; nor will any such failure prejudice Seller's right to enforce that provision in the future. Invalidation of any provision of these Terms by legislation or other rule of law shall not invalidate any other provision herein and, the remaining provisions will remain in full force and effect.

17. Termination. Seller may terminate any agreement governed by or arising from these Terms for any reason and at any time by giving Buyer thirty (30) days prior written notice. Seller may immediately terminate, in writing, if Buyer: (a) breaches any provision of these Terms (b) appoints a trustee, receiver or custodian for all or any part of Buyer's property (c) files a petition for relief in bankruptcy on its own behalf, or one if filed by a third party (d) makes an assignment for the benefit of creditors; or (e) dissolves its business or liquidates all or a majority of its assets.

18. Ownership of Software. Seller retains ownership of all Software supplied to Buyer hereunder. In no event shall Buyer obtain any greater right in and to the Software than a right in the nature of a license limited to the use thereof and subject to compliance with any other terms provided with the Software.

19. Indemnity for Infringement of Intellectual Property Rights. Seller is not liable for infringement of any patents, trademarks, copyrights, trade dress, trade secrets or similar rights ("Intellectual Property Rights") except as provided in this Section. Seller will defend at its expense and will pay the cost of any settlement or damages awarded in an action brought against Buyer based on a third party claim that one or more of the Products sold hereunder infringes the Intellectual Property Rights of a third party in the country of delivery of the Products by the Seller to the Buyer. Seller's obligation to defend and indemnify Buyer is contingent on Buyer notifying Seller within ten (10) days after Buyer becomes aware of any such claim, and Seller having sole control over the defense of the claim including all negotiations for settlement or compromise. If one or more Products sold hereunder is subject to such a claim, Seller may, at its sole expense and option, procure for Buyer the right to continue using the Products, replace or modify the Products so as to render them non-infringing, or offer to accept return of the Products and refund the purchase price less a reasonable allowance for depreciation. Seller has no obligation or liability for any claim of infringement: (i) arising from information provided by Buyer; or (ii) directed to any Products provided hereunder for which the designs are specified in whole or part by Buyer; or (iii) resulting from the modification, combination or use in a system of any Products provided hereunder. The foregoing provisions of this Section constitute Seller's sole and exclusive liability and Buyer's sole and exclusive remedy for such claims of infringement of Intellectual Property Rights.

20. Governing Law. These Terms and the sale and delivery of all Products are deemed to have taken place in, and shall be governed and construed in accordance with, the laws of the State of Ohio, as applicable to contracts executed and wholly performed therein and without regard to conflicts of laws principles. Buyer irrevocably agrees and consents to the exclusive jurisdiction and venue of the courts of Cuyahoga County, Ohio with respect to any dispute, controversy or claim arising out of or relating to the sale and delivery of the Products.

21. Entire Agreement. These Terms, along with the terms set forth in the main body of any Quote, forms the entire agreement between the Buyer and Seller and constitutes the final, complete and exclusive expression of the terms of sale. In the event of a conflict between any term set forth in the main body of a Quote and these Terms, the terms set forth in the main body of the Quote shall prevail. All prior or contemporaneous written or oral agreements or negotiations with respect to the subject matter shall have no effect. These Terms may not be modified unless in writing and signed by an authorized representative of Seller.

22. Compliance with Laws. Buyer agrees to comply with all applicable laws, regulations, and industry and professional standards, including those of the United States of America, and the country or countries in which Buyer may operate, including without limitation the U.S. Foreign Corrupt Practices Act ("FCPA"), the U.S. Anti-Kickback Act ("Anti-Kickback Act"), U.S. and E.U. export control and sanctions laws ("Export Laws"), the U.S. Food Drug and Cosmetic Act ("FDCA"), and the rules and regulations promulgated by the U.S. Food and Drug Administration ("FDA"), each as currently amended. Buyer agrees to indemnify, defend, and hold harmless Seller from the consequences of any violation of such laws, regulations and standards by Buyer, its employees or agents. Buyer acknowledges that it is familiar with all applicable provisions of the FCPA, the Anti-Kickback Act, Export Laws, the FDCA and the FDA and certifies that Buyer will adhere to the requirements thereof and not take any action that would make Seller violate such requirements. Buyer represents and agrees that Buyer will not make any payment or give anything of value, directly or indirectly, to any governmental official, foreign political party or official thereof, candidate for foreign political office, or commercial entity or person, for any improper purpose, including the purpose of influencing such person to purchase Products or otherwise benefit the business of Seller. Buyer further represents and agrees that it will not receive, use, service, transfer or ship any Product from Seller in a manner or for a purpose that violates Export Laws or would cause Seller to be in violation of Export Laws.

PARKER CHOMERICS WORLDWIDE

Corporate Facilities

To place an order please contact a customer service representative at the following locations:

North America

Global Division Headquarters

77 Dragon Court
Woburn, MA
Phone +1 781-935-4850
Fax +781-933-4318
chomailbox@parker.com

Product Disclosure

(RoHS/REACH, Material
Declarations, SDS)
choproductdisclosure@parker.com

Europe

Parker Hannifin Ltd

Chomerics Division Europe
Unit 6, Century Point
Halifax Road
High Wycombe
Bucks HP12 3SL
UK
Phone +44 1494 455400
Fax +44 14944 55466
chomerics_europe@parker.com

Asia Pacific

Parker Hannifin

Chomerics Shanghai
280 Yunqiao Road, Jin Qiao Export
Processing Zone, Shanghai 201206,
China
Phone +86 21 2899 5000
Fax +86 21 2899 5146
chomerics_ap@parker.com

Parker Hannifin

Chomerics Shenzhen
No.5 Bldg Jinrongda Technological Park
Gangtou Village, Bantian Longgang
District Shenzhen, 518122
China
Phone +86 755 8974 8558
Fax +86 755 8974 8560
chomerics_ap@parker.com

Parker Hannifin

Chomerics Kuala Lumpur
Lot 15, Jalan Gudang 16/9
Section 16, Shah Alam
Industrial Estate, 40200 Shah Alam
Selangor, Malaysia
Phone +603 5510 9188
Fax +603 5512 6988
chomerics_ap@parker.com

Penang, Malaysia

No.3, Puncak Perusahaan 1, 13600
Prai, Penang, Malaysia
Phone +604 398329
Fax +604 3983299
chomerics_ap@parker.com

Parker Hannifin India Private Limited

Chomerics Division
Plot No. 41/2, 8th Avenue DTA,
Anjur Village, Mahindra World City,
Chengalpattu, Tamilnadu - 603 004,
India
Phone +91 44 67132333
Phone +91 44 67132045
chomerics_ap@parker.com

Manufacturing Facilities

Woburn, MA; Hudson, NH; Cranford, NJ; Fairport, NY; Monterrey, Mexico; Grantham, UK; High Wycombe, UK; Saint Ouen L'Aumone, France; Sadska, Czech Republic; Shanghai, PRC; Shenzhen, PRC; Penang, Malaysia; Kuala Lumpur, Malaysia; Chennai, India.

www.parker.com/chomerics

© 2020 Parker Hannifin Corporation. All rights reserved.
CHOMERICS is a registered trademark of Parker Hannifin Corporation.

TB1200 EN



ENGINEERING YOUR SUCCESS.